

ADVANTAGES

DRIER PRODUCT

High efficiency produces a dry product, making conveying and stockpiling easy.

LESS POWER

At 2-15 HP depending on the Model, the ORTNER uses about 1/5 of the power used by conventional dewatering machines.

HIGH CAPACITY

The ORTNER has unmatched performance and flexibility.

LESS WATER

Water usage is only about 1/3 as much as required by conventional dewatering equipment.

LESS WEAR

The simple design of the ORTNER results in the lowest wear and maintenance costs.

COMPACT AND LIGHTWEIGHT

The ORTNER is easy to transport and install.



THE ORTNER®

Features

- Low Water Usage
- Low Power Needs
- Low Maintenance
- Low Product Moisture

Capacities

MODEL	CAPACITY (TPH)	HP	WEIGHT (LB)
2000	10-30	2	5,000
2500	30-70	5	9,000
3000	50-125	5	10,000
3500	80-170	10	14,000
4000	120-210	15	18,000

Aggregates Equipment, Inc.

P.O. Box 39, Leola, PA 17540

Phone: 717-656-2131

Fax: 717-656-6686

website: www.aggregatesequipment.com

Email: sales@aggregatesequipment.com

*Excess Fines?
Ortner them out!*



THE ORTNER®

- Dewateres
- Removes Fines
- Classifies
- Rinses

All in one!

AEI

The most cost effective way to dewater, remove fines, classify, and rinse.

The ORTNER is designed to dewater and remove fines, classify, and rinse sand and other fine materials. The ORTNER uses much less water than other dewatering and classifying machines, and consumes far less power, creating significant savings for the operator.



When fed a wet slurry from a density separator or hydrocyclone, the ORTNER may be used to dewater, classify, or remove excess fines from the slurry.

Dry sand may be fed to the ORTNER to remove excess fines. Coarse material, up to 3", can be dedusted by adding a small quantity of water.

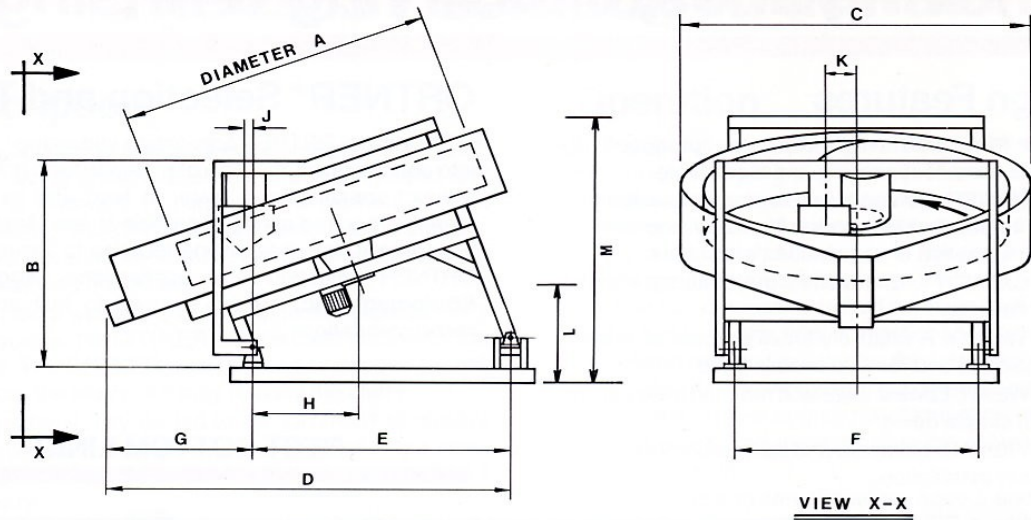

Dimensions (inches)

MODEL	A	B	C	D	E	F	G	H	J	K	L	M
2000	79	67	90	103	70	67	33	28	2	9	33	73
2500	99	83	110	138	98	95	40	41	3	11	35	106
3000	118	79	130	151	98	95	53	43	5	11	35	105
3500	138	89	152	179	115	111	64	49	4	12	37	116
4000	158	94	172	194	131	126	63	58	6	14	42	125

HOW IT WORKS

Material is fed into a slowly revolving inclined pan, and vibrated at high speed. The high speed quickly separates the various sizes of material, with the fines and water rising to the top and discharging over the pan's edge. The coarser material sinks to the bottom, where the settled particles are carried by the rotating pan up and out of the water. A stationary plow diverts the dewatered material to a central discharge spout.

The driving and vibrating mechanisms are mounted under the pan. This prevents contamination with the water and processed material, and increases the life of these components.

The ORTNER allows for many adjustments to meet changing sand specifications properties. By adjusting the pan angle, rotational speed, and vibration, the ORTNER gives greater flexibility, capacity and efficiency.

